

# THE ARTS OF ISLAM

## TREASURE HUNT



ART  
GALLERY  
NSW

HAVE FUN EXPLORING  
THE ARTS OF ISLAM: TREASURES FROM  
THE NASSER D KHALILI COLLECTION  
AND MAKE SOME ART OF YOUR OWN

**Collect**  
a pencil



**Go** on a journey  
through the  
exhibition



**Discover**  
the Islamic  
treasures

★ **Look, draw and have fun!**



## THE ARTS OF ISLAM TREASURES FROM THE NASSER D KHALILI COLLECTION

Discover the exquisite beauty and intricate detail of Islamic art  
on your own treasure hunt.

above: *Jonah and the whale* from *Jami al-Tawarikh* by Rashid al-Din, Iran, Tabriz,  
dated 714 AH (1314–15 AD), ink, translucent and opaque watercolour, gold and silver on paper  
cover: *Mother-of-pearl-inlaid casket* India, Gujarat, 16th century AD, teak, mother-of-pearl,  
black lacquer, gilt metal, 20 x 33.4 x 19.7 cm

★ **Locate** these bowls and dishes.

They are over 1000 years old and would have been used for special occasions.

What animals can you **spot**?  
Are they **repeated** exactly around the dish?

**Look** closely at the decorations on these and other examples of pottery.

**Design** your own special bowl using a repeat pattern of your favourite animal.

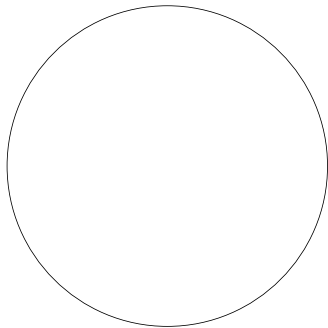

top to bottom: Dish with lustre decoration Iraq, 9th or 10th century AD, buff-bodied earthenware, with monochrome lustre decoration over an opaque white glaze, 3 x 31.7 cm (diameter); Bowl Iran, Nishapur, 10th or 11th century AD, earthenware, slip painted under a colourless lead glaze 13.4 x 39.4 cm (diameter); Bowl with lustre decoration Iraq, 9th or 10th century AD, buff-bodied earthenware, with monochrome lustre decoration over an opaque white glaze, 8 x 26 cm (diameter).

**At home look** at examples of pottery your family owns. Are any of them similar to the ones in the exhibition? Draw your favourite one.



★ **Here** are some elaborate earrings made of gold wire.

They are very old and rare.

**Observe** how thin gold wire has been **twisted** to make patterns and shapes. Do you think they would be heavy or light to wear? Why?

**Imagine** who might have worn these earrings and where they wore them. **Draw** a picture of them here.



*Pair of earrings with pendant chains Syria, 10th or 11th century AD gold filigree, 10 cm (height)*

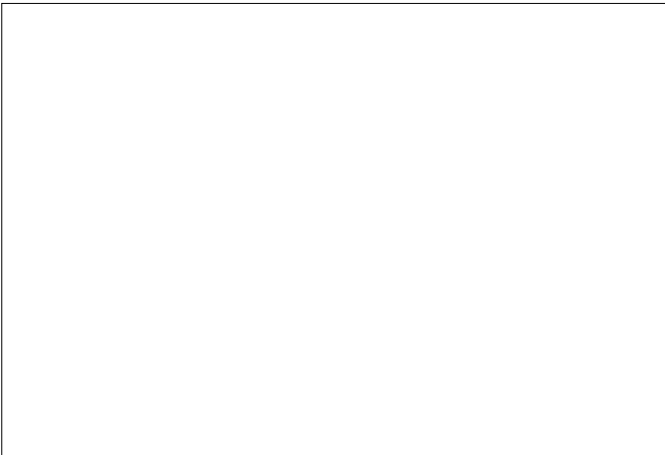

**At home twist** together some pipe cleaners or thin wire to create your own delicate pattern to make a piece of jewellery.



★ **Look** at this water jug in the shape of a goose.

Can you **see** where you pour the water into this jug?

**Search** the exhibition for other examples of vases, jugs and vessels in the shape of animals and birds. Which one is your favourite?

**Invent** your own animal-shaped jug below.

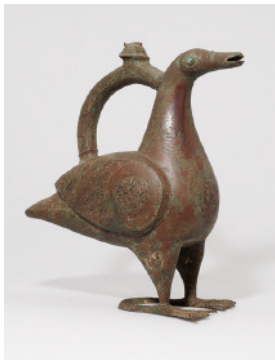

*Aquamanile in the form of a goose signed by the Herati craftsmen, Abu'l-Qasim ibn Muhammad al-Harawi, Iran, Khurasan, 12th century AD, Quaternary copper alloy with surface engraving and traces of black compound, with inlay of turquoise-glazed pottery for the bird's eyes, 37 x 28,5 x 14 cm*

**At home sketch** your own pet or animals and birds from your imagination. Simplify into shapes and design a vase based on your sketches.



★ **Find** this crowned head.

Crowned head Central Asia, 8th or 9th century AD, limestone, carved and painted, 30 cm (height)



This head was once part of a carved stone frieze that decorated a palace wall.

**Imagine** what the body of this figure may have looked like.

**Look** closely at the shapes and patterns on this crown and other stone carvings in the exhibition.

**Design** a new crown for this figure using some of the patterns you found.

**At home find out** what Islamic palaces look like. Make your own palace out of cardboard and decorate its walls with Islamic-style patterns.



★ **Here** is Jonah being swallowed by a whale.

Jonah was a teacher of God's (Allah's) will and was sent to warn the people of Nineveh to change their bad ways. In the story, sailors believe Jonah is the reason for a big storm so he is thrown overboard and is swallowed by a large fish or whale.

**Observe** how the water in this painting swirls and curls to show the storm. **Describe** how you think Jonah might feel at this terrible moment.



**Find** other paintings near this one with boats in them. Use them to **inspire** you to draw Jonah in his boat just before he is thrown into the stormy sea.

*Jonah and the whale* from Jami al-Tawarikh by Rashid al-Din, Iran, Tabriz, dated 714 AH (1314–15 AD), ink, translucent and opaque watercolour, gold and silver on paper

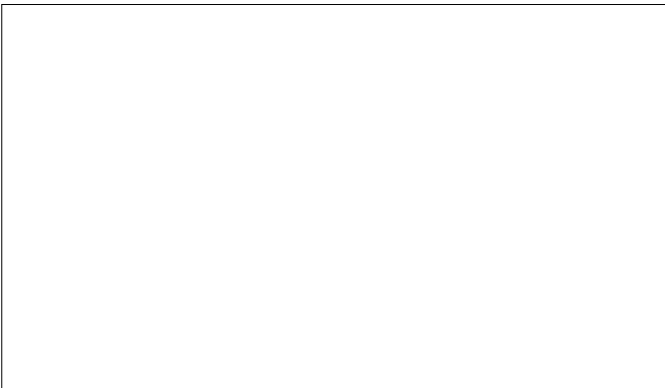

**At home find out** more about Jonah's amazing story and draw your favourite scenes.



★ **Meet** the mythical hero Rustam and his horse Rakhsh.

Rustam is a character in a famous Islamic storybook called *The Book of Kings*.

Rustam and Rakhsh have to go on a long journey and face many challenges along the way such as slaying a dragon.

**Find** these things and **tick** them as you find them:

- Birds
- A leopard-shaped helmet
- A feather
- Red flowers
- A hollow tree
- Calligraphy



Rustam aided by his horse Rakhsh, slays a dragon from the 'Houghton' Shahnamah, Iran, Tabriz, 1520s, ink, gold, and opaque watercolour on paper, 47 x 31.8 cm

**At home find** other stories that have dragons in them. Read some of them and discover what dragons look like. Are they always the same? Draw your favourite dragon or invent your own.



THE ARTS OF ISLAM: TREASURES FROM  
THE NASSER D KHALILI COLLECTION

ART GALLERY OF NEW SOUTH WALES  
22 JUNE - 23 SEPTEMBER 2007

Principal sponsors: Westfield, NAB  
Supported by: VisAsia Council, President's Council, Qantas, Delta Electricity

Written by Victoria Collings, designed by Karen Hancock  
©Public Programs Department Art Gallery of New South Wales 2007



★ **Encounter** this amazing lion.

His body is made of special letters called **calligraphy**.

If you were an animal, which one would you like to be?

**Write** your name in the **shape** and **outline** of the animal you have chosen.



Calligraphic composition in the form of a lion signed by the calligrapher Ahmed Hilmi, Ottoman, Turkey, dated 12 Jumada 1 1331 AH (19 April 1913 AD), ink and colour on paper, 26.5 x 38.8 cm

**At home practice** writing your name in different decorative styles of lettering.



★ **Examine** this intricate casket.

Caskets such as this one would have been treasured because their decorations were so complicated and precious. What do you think was placed inside them?

**Locate** other decorative boxes and chests in the exhibition and **compare** their designs.

**Decorate** this chest below with patterns from plants, flowers and shapes.



*Mother-of-pearl-inlaid casket India, Gujarat, 16th century AD, teak, mother-of-pearl, black lacquer, gilt metal, 20 x 33.4 x 19.7 cm*

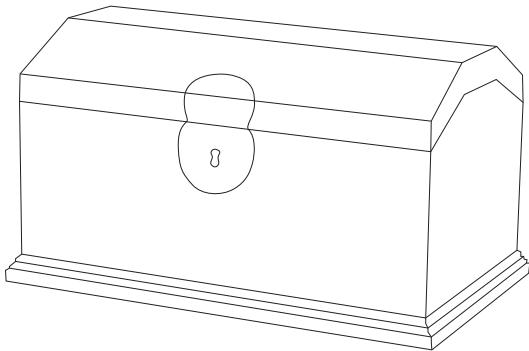

**At home make** your own treasure chest out of a small box. Decorate it with sequins and jewels and use it to keep something special in.



★ **Here** is a colourful ceramic tile.

Tiles such as this one decorated royal palaces, fountains and courtyard gardens.

**Visualise** what a whole wall of these tiles would have looked like.

**Extend** the pattern of this tile across the rest of these blank tiles and invent a border to go along the top of them.

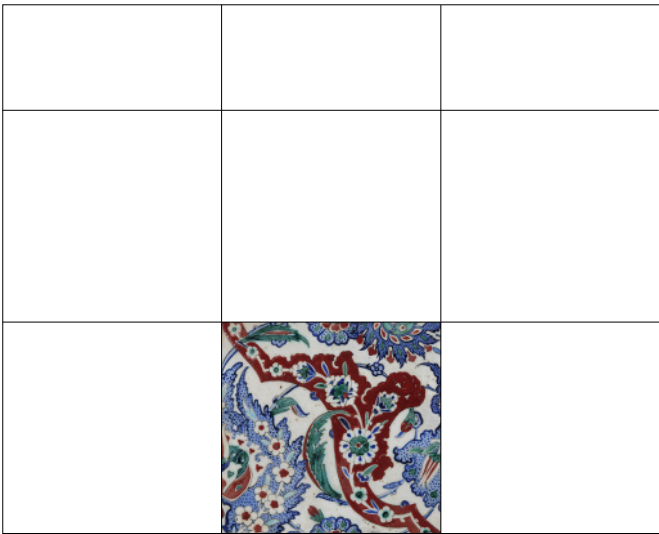

*Tile from a frieze Ottoman Turkey, Iznik, c.1560–80 AD, stonepaste body, decorated underglaze in black, blue, green and bole-red, 26 x 27.5 x 1 cm*

**At home invent** your own design for a tiled courtyard garden, complete with a fountain and paint your idea.



★ **Look** closely at this beautiful carpet.

It was probably made for a king as it is so elaborate.

Can you **spot** the prowling lions **hidden** within the flowers?

**Use** the template below to **create** a carpet fit for a king or queen.

**Imagine** this carpet is a magic flying carpet. Where could it take you?

**Tell** a tale about your adventures.



Medallion carpet Iran, perhaps Kashan, 16th century AD, wool pile, with metal thread on silk foundation 248 x 199 cm

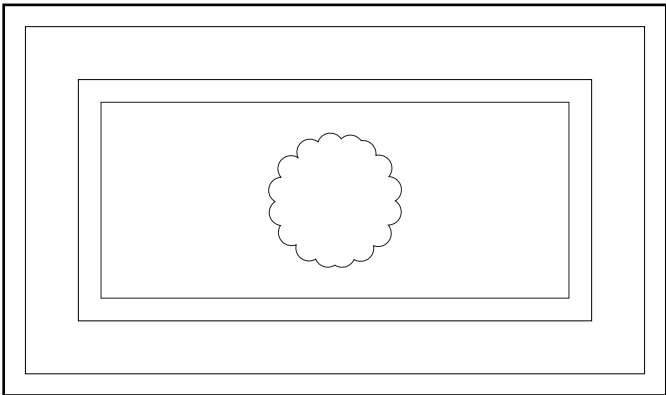

**At home find** stories from *The Arabian Nights* and discover magical stories about adventures and flying carpets.

